

# Heritage® Print Storage Boxes

## T16: Custom Two-Piece Box

Assembly Instructions

- ① Place flat box white side facing up. The crease lines should be visible, and the blue/gray side of the board facing down.

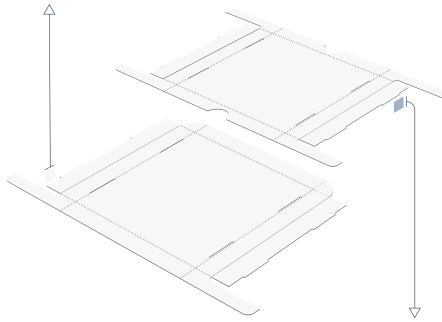

- ② Pre-crease all lines prior to snapping any walls into place. Pay extra attention to the double crease lines which are approximately 1/4" apart along the doubled over walls. It is critical that both crease lines are folded at a full 90° or more.

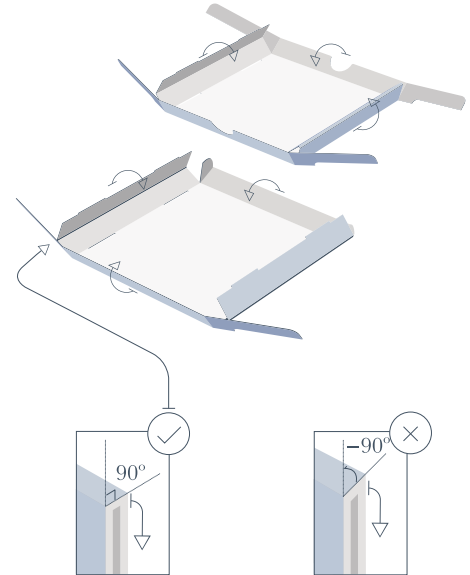

- ③ Begin folding together the box. Fold the single thick walls up first. The flaps that extend from these walls should be folded at 90°.

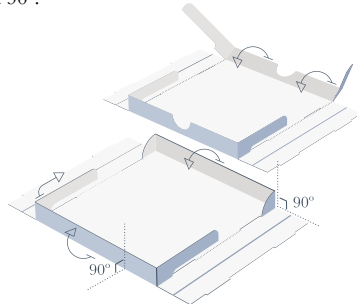

- ④ Now fold the doubled over walls. When assembled, the flaps should be sandwiched inside of these walls.

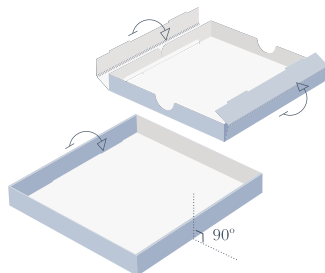

- ⑤ Make sure all sides are square, and all walls are properly creased. On the double walls, if only one crease is folded, the tabs will either be too long or too short depending on which line was folded.

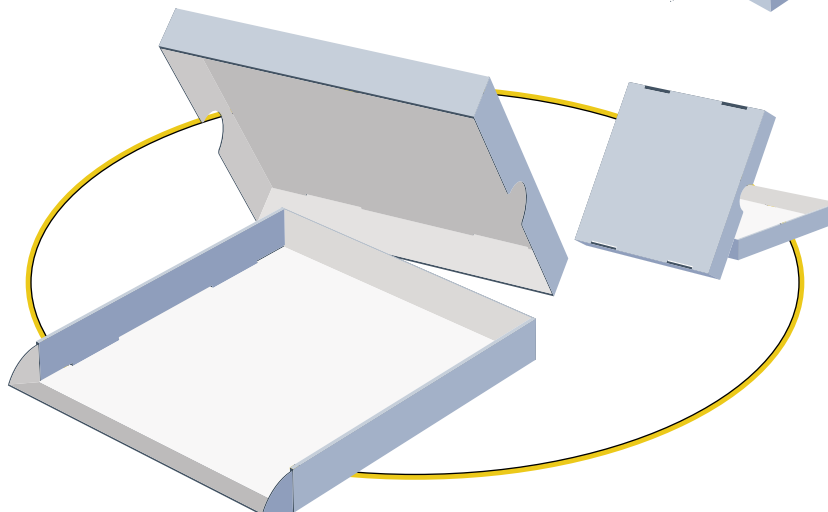
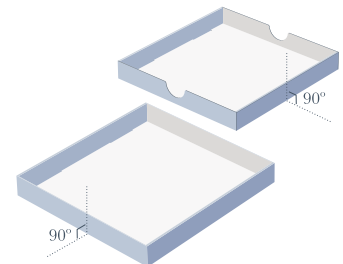

**Related Products:**

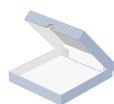

**Heritage® Clamshell Box**  
T03: Custom Archival Clamshell Box

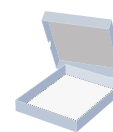

**Heritage® Reinforced Box**  
T12: Custom Reinforced Two-Piece Box